

CAD FILE:

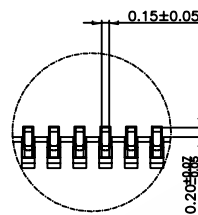

DETAIL C
SCALE 3:1

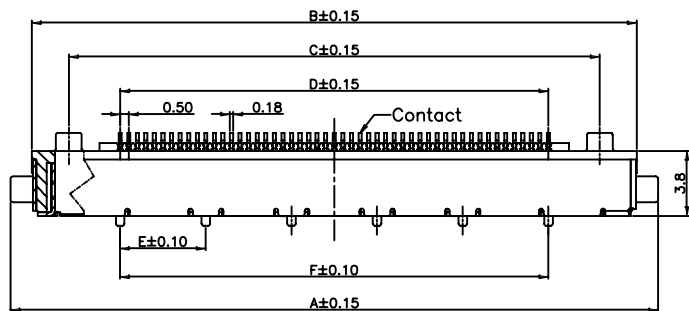
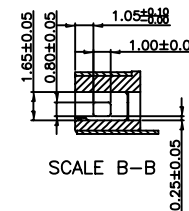

SCALE B-B

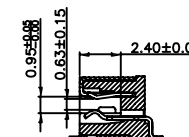
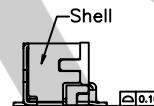
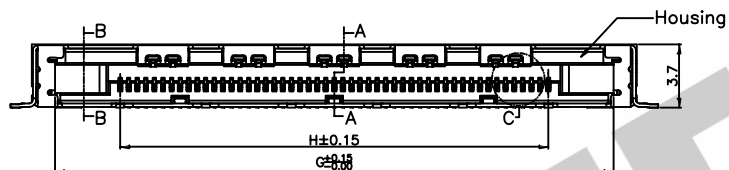

SCALE A-A

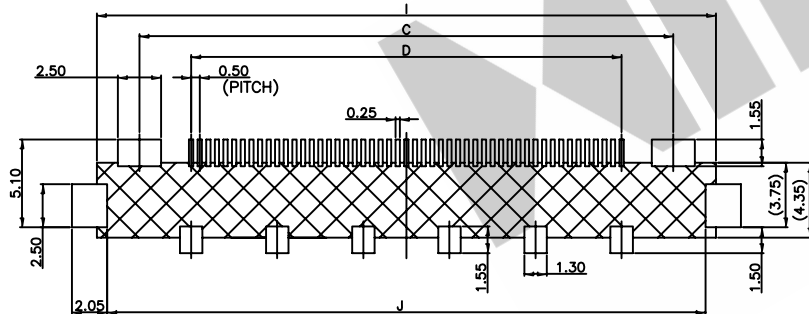

RECOMMEND P.C.B LAYOUT

Dimension(mm)

PIN	A	B	C	D	E	F	G	H	I	J
41	32.80	30.35	26.00	20.00	4.00	20.00	27.65	20.00	30.95	29.75
51	37.80	35.35	31.00	25.00	5.00	25.00	32.65	25.00	35.95	34.75

TOLERANCE UNLESS SPECIFIED		SHENZHEN XIEJIA ELECTRONICS CO.,LTD.				
WITHIN: 1.5±0.1mm OVER: 1.5±0.2mm		ISSUE	DATE	DESCRIPTIONS OF REVISION		APPD
TITLE: LVDS CONNECTOR			UNIT : mm	DRWG NO.:XJ-LVDS05-41/51-A		
MODEL: Pitch0.5-51PIN FI-RE WF H3.75MM			SCALE: 1:3	DWN	ZHOUYU	2012-11-20
ALL MATERIALS MUST BE COMPLIANT TO ROHS			CHK'D	FANGYING	2012-11-20	
			APPD	KANGXINAN	2012-11-20	

NO.	PARTS	MATERIALS	QTY	FINISH
3	CONTACT	PHOSPHOR BRONZE	41/51	GOLD PLATED
2	SHEEL	SUS304R-3/4H	1	Tin PLATED
1	HOUSING	LCP (UL94V-0)	1	BLACK

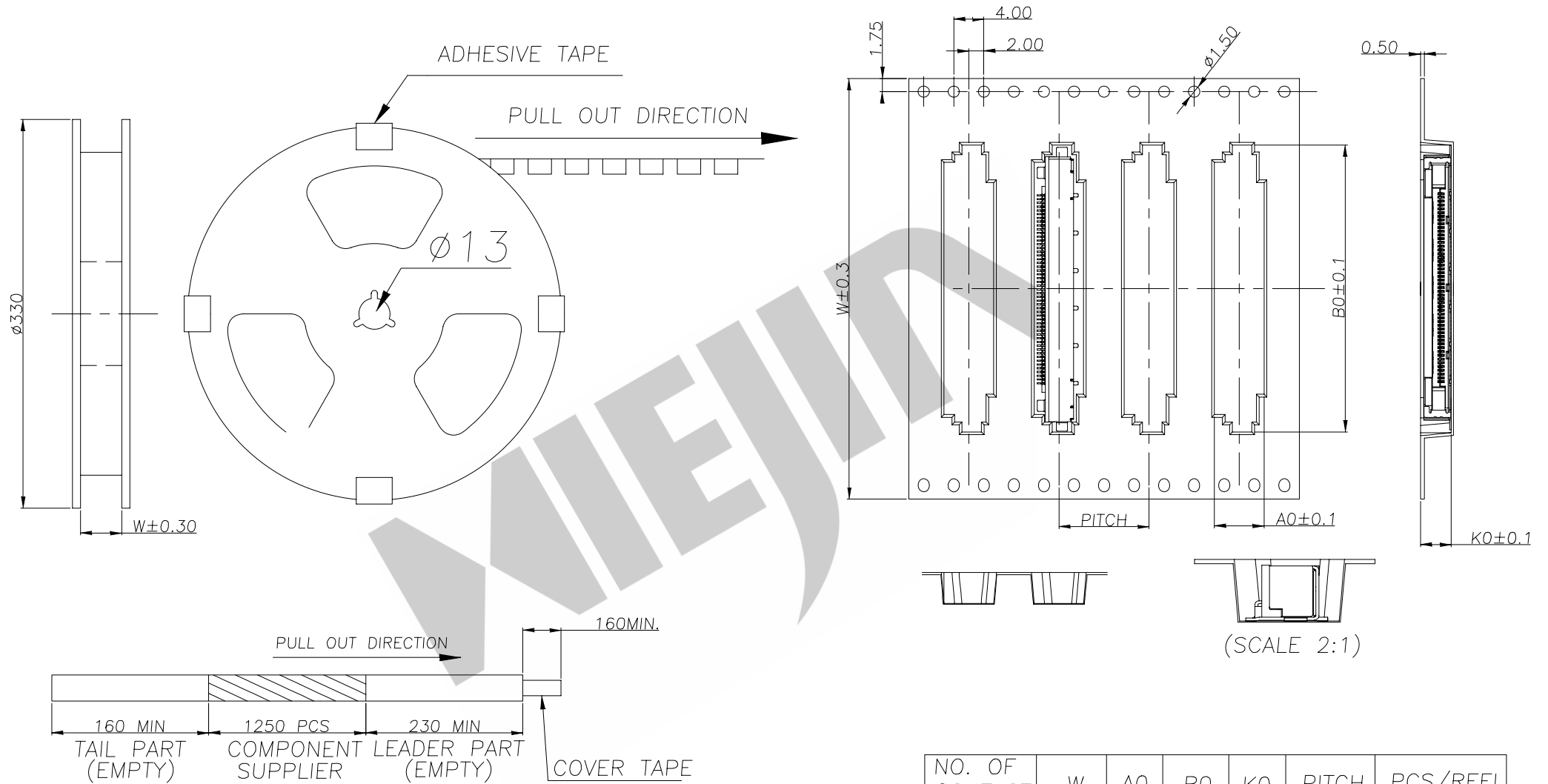

NO. OF CONTACT	W	A0	B0	K0	PITCH	PCS/REEL
51	56.0	6.6	38.2	4.1	12.0	1250 PCS
41	51.0		33.2			

SHENZHEN XIEJIA ELECTRONICS CO.,LTD.

TOLERANCE
UNLESS SPECIFIED

TITLE : LVDS Connector

UNIT : mm

DRWG NO.: XJ-DR-FPC0.5-41/51P

MODEL: LVDS Pitch0.5-xxPIN,H3.75

SCALE: 8:1

DWN. ZHOUYU 2012-11-20

WITHIN: 1.5 ± 0.1 mm

OVER: 1.5 ± 0.2 mm

ALL MATERIALS MUST BE COMPLIANT TO ROHS

CHK'D FANGYING 2012-11-20

APPD. KANGXINAN 2012-11-20

ISSUE	DATE	DESCRIPTIONS OF REVISION	APPD.

包装步骤:

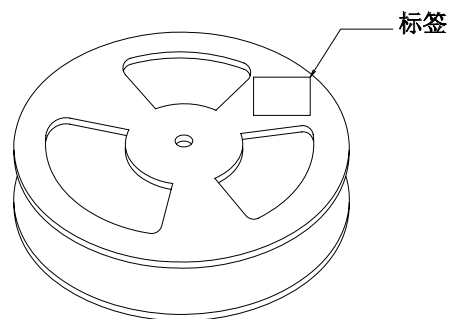

(1000PCS/Reel)

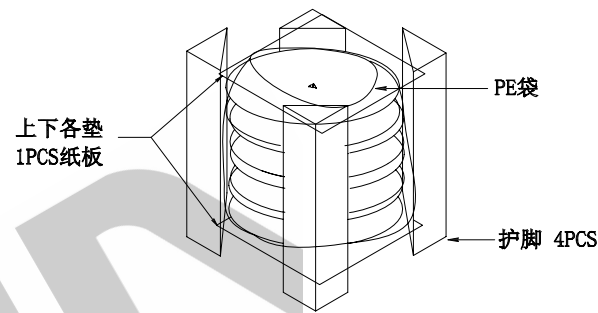

1. 产品装盘后在轮盘上贴上标签

2. 把步骤1贴好标签的产品按图示用PE袋包好, 并放入两包干燥剂后装箱

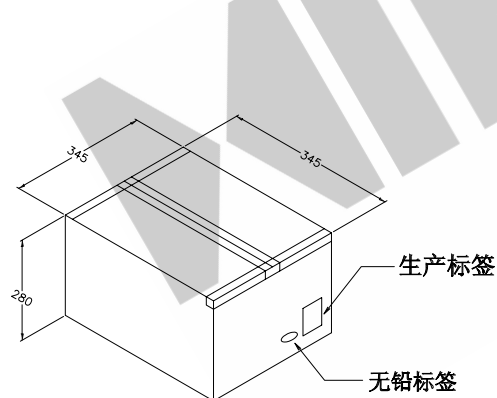

3. 将打包好的产品在外箱贴上生产标签与无铅标签品, 保检验后入库

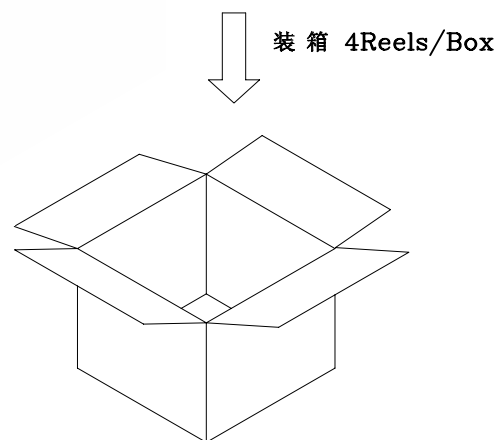

SHENZHEN XIEJIA ELECTRONICS CO.,LTD.				TOLERANCE UNLESS SPECIFIED		TITLE : LVDS Connector		UNIT : mm		DRWG NO.: XJ-DR-FPC0.5-41/51P	
				WITHIN: 1.5±0.1mm		MODEL: LVDS Pitch0.5-xxPIN,H3.75		SCALE: 8:1		DWN. ZHOUYU 2012-11-20	
				OVER: 1.5±0.2mm		ALL MATERIALS MUST BE COMPLIANT TO ROHS				CHK'D FANGYING 2012-11-20	
ISSUE	DATE	DESCRIPTIONS OF REVISION	APPD.							APPD. KANGXINAN 2012-11-20	